

> RHA

AIR-WATER CHILLERS AND HEAT PUMPS FOR OUTDOOR INSTALLATION



Available range

Unit type

IR	Chiller
IP	Heat pump (reversible on the refrigerant side)
BR	Chiller Brine
BP	Heat pump Brine (reversible on the refrigerant side)

Version

VB	Base version
VD	Desuperheater version
VR	Total recovery version

Acoustic setting up

AB	Base setting up
AS	Low noise setting up
AX	eXtra low noise setting up

Source temperature level

M	Medium temperature level
A	High temperature level

Unit description

This series of air-water chillers and heat pumps satisfies the cooling and heating requirements of residential plants of large size.

All the units are suitable for outdoor installation and can be applied to fan coil plants, radiant floor plants and high efficiency radiators plants.

The refrigerant circuit, contained in a compartment protected from the air flow to simplify the maintenance operations, is equipped with scroll compressors mounted on damper supports, brazed plate heat exchanger, electronic expansion valve, reverse cycle valve, dehydrator

filter, axial fans with safety protection grilles, finned coil made of copper pipes and aluminium louvered fins. The circuit is protected by a safety gas valve, high and low pressure switches and differential pressure switch on the plate heat exchanger.

The plate heat exchanger and all the hydraulic pipes are thermally insulated in order to avoid condensate generation and to reduce thermal losses.

All the units can be equipped with variable speed fans control that allows the units to operate with low outdoor temperatures in cooling and high outdoor temperature in heating and permits to reduce noise emissions in such operating conditions.

The low noise acoustic setting up (AS) is obtained, starting from the base setting up (AB), reducing the rotational speed of the fans and mounting sound jackets on the compressors and the technical compartment is clad with soundproofing material of suitable thickness.

The eXtra low noise acoustic setting up (AX) is obtained, starting from the low noise setting up (AS), further reducing the rotational speed of the fans and using finned coil with bigger surface.

All the units are supplied with a management and control electrical panel containing general switch, phase presence and correct sequence controller, microprocessor controller with display and all the other electrical components with IP54 minimum protection degree.

All the units are accurately built and individually tested in the factory. Only electric and hydraulic connections are required for installation.

Options

Storing and pumping module available in the configurations :

- storage tank arranged as buffer on the flow or as primary-secondary buffer
- 1 or 2 pumps
- standard or high head pump
- **Refrigerant circuit pressures visualization**
- high and low pressure gauges
- high and low pressure transducers

High temperature thermostat

Compressor starting

- standard (contactors)
- soft starter

Fans control

- on-off control
- modulating control (condensation / evaporation control) standard for AS and AX unit

Compressor power factor correction

Electrical load protection

- fuses
- thermal magnetic circuit breakers

Accessories

Rubber vibration dampers

Spring vibration dampers

Coil protection grilles

Tank antifreeze electrical heater

Remote control

Modbus serial interface on RS485

Programmer clock

Phase sequence and voltage controller

Water flow switch

Victaulic hydraulic fittings

NET NOMINAL performances - Standard plants - EUROVENT certified data

IR	Base setting up (AB)	350.5	390.6	440.6	490.6	560.6	630.6	
A35W7	Cooling capacity	348	371	436	489	554	619	kW
	Power input	123	131	152	174	193	219	kW
	EER	2,83	2,83	2,87	2,81	2,87	2,83	W/W
	ESEER	3,90	3,90	3,93	3,90	3,94	3,91	W/W
	Water flow rate	16,8	17,9	21,0	23,6	26,7	29,9	l/s
	Pressure drops	47	54	48	60	45	56	kPa
IR	Low noise setting up (AS)	350.5	390.6	440.6	490.6	560.6	630.6	
A35W7	Cooling capacity	335	356	418	470	532	595	kW
	Power input	129	140	162	185	207	233	kW
	EER	2,60	2,54	2,58	2,54	2,57	2,55	W/W
	ESEER	3,78	3,74	3,77	3,74	3,76	3,75	W/W
	Water flow rate	16,1	17,2	20,1	22,6	25,6	28,7	l/s
	Pressure drops	43	50	44	55	41	52	kPa
IR	eXtra low noise setting up (AX)	350.5	390.6	440.6	490.6	560.6	630.6	
A35W7	Cooling capacity	328	349	410	460	522	583	kW
	Power input	133	144	166	190	211	239	kW
	EER	2,47	2,42	2,47	2,42	2,47	2,44	W/W
	ESEER	3,87	3,84	3,89	3,84	3,88	3,86	W/W
	Water flow rate	15,8	16,8	19,7	22,2	25,1	28,1	l/s
	Pressure drops	42	47	42	53	40	49	kPa
IP	Base setting up (AB)	350.5	390.6	440.6	490.6	560.6	630.6	
A35W7	Cooling capacity	339	361	423	476	536	603	kW
	Power input	120	130	151	171	191	216	kW
	EER	2,83	2,78	2,80	2,78	2,81	2,79	W/W
	ESEER	3,85	3,83	3,84	3,84	3,85	3,85	W/W
	Water flow rate	16,3	17,4	20,4	22,9	25,8	29,0	l/s
	Pressure drops	45	51	45	57	42	53	kPa
A7W45	Heating capacity	373	397	460	521	580	664	kW
	Power input	123	132	152	174	192	223	kW
	COP	3,03	3,01	3,03	2,99	3,02	2,98	W/W
	Water flow rate	17,7	18,8	21,8	24,7	27,5	31,4	l/s
Pressure drops	53	59	51	66	48	62	kPa	
IP	Low noise setting up (AS)	350.5	390.6	440.6	490.6	560.6	630.6	
A35W7	Cooling capacity	325	346	406	457	515	579	kW
	Power input	128	138	161	183	204	231	kW
	EER	2,54	2,51	2,52	2,50	2,52	2,51	W/W
	ESEER	3,70	3,69	3,69	3,67	3,67	3,69	W/W
	Water flow rate	15,6	16,7	19,5	22,0	24,7	27,9	l/s
	Pressure drops	41	47	41	52	38	49	kPa
A7W45	Heating capacity	358	380	441	500	557	638	kW
	Power input	118	125	145	166	184	213	kW
	COP	3,03	3,04	3,04	3,01	3,03	3,00	W/W
	Water flow rate	17,0	18,0	20,9	23,7	26,4	30,2	l/s
Pressure drops	48	54	47	61	44	57	kPa	
IP	eXtra low noise setting up (AX)	350.5	390.6	440.6	490.6	560.6	630.6	
A35W7	Cooling capacity	319	340	397	447	505	568	kW
	Power input	131	140	165	187	209	236	kW
	EER	2,44	2,43	2,41	2,39	2,42	2,41	W/W
	ESEER	3,83	3,81	3,79	3,79	3,79	3,79	W/W
	Water flow rate	15,3	16,3	19,1	21,5	24,3	27,3	l/s
	Pressure drops	39	45	39	50	37	47	kPa
A7W45	Heating capacity	355	376	436	495	551	631	kW
	Power input	116	123	142	163	180	209	kW
	COP	3,06	3,06	3,07	3,04	3,06	3,02	W/W
	Water flow rate	16,8	17,8	20,7	23,4	26,1	29,9	l/s
Pressure drops	47	53	46	59	43	56	kPa	

Data declared according to **EN 14511**. The values are referred to units without options and accessories.
EER (Energy Efficiency Ratio) = ratio of the total cooling capacity to the effective power input of the unit
COP (Coefficient Of Performance) = ratio of the total heating capacity to the effective power input of the unit

ESEER (European Seasonal Energy Efficiency Ratio)

_____ = Unit in **A CLASS**.

A35W7 = source : air in 35°C d.b. / plant : water in 12°C out 7°C

A35W18 = source : air in 35°C d.b. / plant : water in 23°C out 18°C

A7W45 = source : air in 7°C d.b. 6°C w.b. / plant : water in 40°C out 45°C

A7W35 = source : air in 7°C d.b. 6°C w.b. / plant : water in 30°C out 35°C

Acoustic performances

Base setting up (AB)	350.5	390.6	440.6	490.6	560.6	630.6	
Sound power level ^(E)	95	95	96	96	97	97	dB(A)
Sound pressure level at 1 meter	75	75	76	76	76	76	dB(A)
Sound pressure level at 5 meters	67	67	68	68	69	69	dB(A)
Sound pressure level at 10 meters	63	63	64	64	65	65	dB(A)
Low noise setting up (AS)	350.5	390.6	440.6	490.6	560.6	630.6	
Sound power level ^(E)	89	89	90	90	91	91	dB(A)
Sound pressure level at 1 meter	69	69	70	70	70	70	dB(A)
Sound pressure level at 5 meters	61	61	62	62	63	63	dB(A)
Sound pressure level at 10 meters	57	57	58	58	59	59	dB(A)
eXtra low noise setting up (AX)	350.5	390.6	440.6	490.6	560.6	630.6	
Sound power level ^(E)	86	86	87	87	88	88	dB(A)
Sound pressure level at 1 meter	66	66	67	67	67	67	dB(A)
Sound pressure level at 5 meters	58	58	59	59	60	60	dB(A)
Sound pressure level at 10 meters	54	54	55	55	56	56	dB(A)

(E): EUROVENT certified data

The acoustic performances are referred to units operating in cooling mode at nominal conditions A35W7.

Unit placed in free field on reflecting surface (directional factor equal to 2).

The sound power level is measured according to ISO 9614 standard.

The sound pressure level is calculated according to ISO 3744 and is referred to a distance of 1/5/10 metres from the external surface of the unit.

Technical data

Unit	350.5	390.6	440.6	490.6	560.6	630.6	
Power supply	400 - 3 - 50						V-ph-Hz
Compressor type	scroll						-
N° compressors / N° refrigerant circuits	5 / 2	6 / 2					n°
Plant side heat exchanger type	stainless steel brazed plates						-
Source side heat exchanger type	finned coil						-
Fans type	axial						-
N° fans	8	10		12			n°
Tank volume	700						l
Hydraulic fittings	4" VICTAULIC						-

Electrical data

Standard unit	350.5	390.6	440.6	490.6	560.6	630.6	
FLA - Full load current at maximum tolerated conditions	287	302	355	399	451	494	A
FLI - Full load power input at maximum tolerated conditions	171	182	211	237	272	304	kW
MIC - Maximum instantaneous current of the unit	538	529	605	649	771	815	A
MIC SS - Maximum instantaneous current of the unit with soft starter options	434	441	508	552	640	684	A
Unit with high head modulating pump	350.5	390.6	440.6	490.6	560.6	630.6	
FLA - Full load current at maximum tolerated conditions	308	323	382	426	478	521	A
FLI - Full load power input at maximum tolerated conditions	184	195	227	253	288	320	kW
MIC - Maximum instantaneous current of the unit	558	550	632	676	798	842	A
MIC SS - Maximum instantaneous current of the unit with soft starter options	558	550	632	676	798	842	A

Operative range

Temperature	Unit type	Cooling		Heating		(°C)
		min	max	min	max	
Outdoor air inlet temperature	IR, BR, IP, BP	-10*	52**	-10	40*	(°C)
Water outlet temperature	IR, IP	5	25	30	55	(°C)
Water outlet temperature	BR, BP	-12	5	30	55	(°C)
Water outlet temperature (VD)	IR, BR, IP, BP	30	70	30	70	(°C)
Water outlet temperature (VR)	IR, BR	30	55	-	-	(°C)

* with fans modulating control option (condensation / evaporation control)

** with ATC outdoor high temperature protection function

VD and VR versions

These units allow to recover the heating power, otherwise wasted on air, through an additional heat exchanger.

The **Desuperheater Version (VD)** allow the hot water production at temperatures between 30 and 70°C through the partial heat recovery of the condensation heat.

The **Total Recovery Version (VR)** allows the cold water production and, at the same time, the hot water production at temperatures between 30 and 55°C through the total recovery of the condensation heat.

Desupeheater Version (VD) - NET NOMINAL performances

IR	Base setting up (AB)	350.5	390.6	440.6	490.6	560.6	630.6	
A35W7 - W45	Cooling capacity	362	385	453	509	576	644	kW
	Total power input	120	129	150	170	189	213	kW
	EER	3,02	3	3,03	2,99	3,06	3,02	W/W
	HRE	3,75	3,72	3,76	3,71	3,79	3,75	W/W
	Water flow rate	17,5	18,6	21,8	24,6	27,8	31,0	l/s
	Water pressure drop	51	58	51	65	49	60	kPa
	Heating recovery capacity	87,7	93,4	110	123	139	156	kW
	Water flow rate recovery	4,19	4,46	5,26	5,88	6,64	7,45	l/s
	Water pressure drop recovery	24	27	25	32	31	39	kPa
IP	Base setting up (AB)	350.5	390.6	440.6	490.6	560.6	630.6	
A35W7 - W45	Cooling capacity	352	376	440	494	558	626	kW
	Total power input	118	126	147	168	187	211	kW
	EER	2,99	2,97	2,98	2,94	2,98	2,97	W/W
	HRE	3,72	3,69	3,7	3,66	3,71	3,69	W/W
	Water flow rate	16,9	18,1	21,2	23,9	26,8	30,2	l/s
	Water pressure drop	48	55	49	62	45	57	kPa
	Heating recovery capacity	85,2	90,7	106	120	135	152	kW
	Water flow rate recovery	4,07	4,33	5,06	5,73	6,45	7,26	l/s
	Water pressure drop recovery	23	26	24	30	29	36	kPa

Total Recovery Version (VR) - NET NOMINAL performances

IR	Base setting up (AB)	350.5	390.6	440.6	490.6	560.6	630.6	
A35W7 - W45	Cooling capacity	362	385	453	509	576	644	kW
	Total power input	104	113	130	150	166	190	kW
	EER	3,48	3,42	3,49	3,38	3,48	3,38	W/W
	HRE	7,92	7,8	7,94	7,72	7,92	7,72	W/W
	Water flow rate	17,5	18,6	21,8	24,6	27,8	31,0	l/s
	Water pressure drop	51	58	51	65	49	60	kPa
	Heating recovery capacity	461	493	577	652	734	824	kW
	Water flow rate recovery	22	23,6	27,6	31,2	35,1	39,4	l/s
	Water pressure drop recovery	52	60	51	66	54	68	kPa

Data declared according to **EN 14511**. The values are referred to units without options and accessories.

EER (Energy Efficiency Ratio) = ratio of the total cooling capacity to the effective power input of the unit

HRE (Heat Recovery Efficiency) = ratio of the total capacity of the system (heating plus cooling capacity) to the effective power input

A35W7 - W45 = source : air in 35°C d.b. / plant : water in 12°C out 7°C / Recovery : water in 40°C out 45°C

CONTROL SYSTEM

The units are equipped with a controller designed to ensure energy saving and unit efficiency. Available functions :

- ATC outdoor high temperature protection function
- Dynamic defrost
- Sound management
- Climatic control in heating and in cooling mode
- Double set point function
- Demand limit
- Integrative heating
- Remote stand by
- Remote cooling-heating



DIMENSIONS - MINIMUM OPERATING AREA - WEIGHT

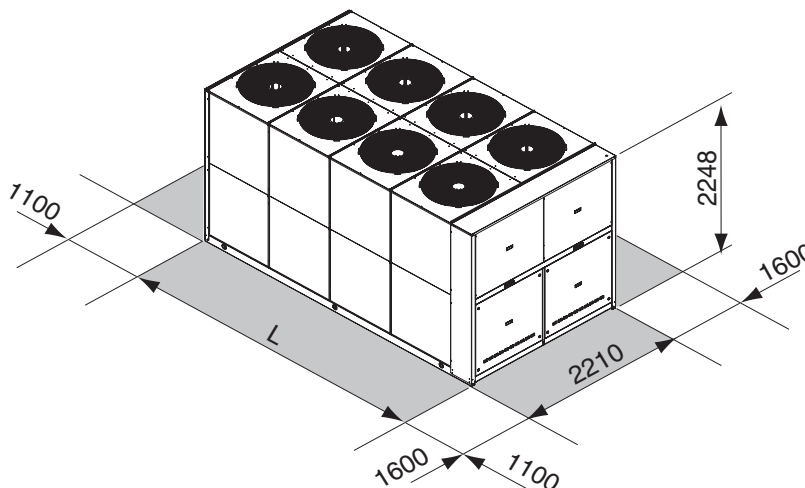

	350.5	390.6	440.6	490.6	560.6	630.6	
L	5030	5030	5030	5030	5963	5963	mm
Operating maximum weight*	4849	5058	5120	5199	5489	5568	kg

* Weight refers to the unit IP with tank and pumping module 2 pumps.

> RHA HE

AIR-WATER CHILLERS AND HEAT PUMPS FOR OUTDOOR INSTALLATION



Available range

Unit type

IR	Chiller
IP	Heat pump (reversible on the refrigerant side)
BR	Chiller Brine
BP	Heat pump Brine (reversible on the refrigerant side)

Version

VB	Base version
VD	Desuperheater version
VR	Total recovery version

Acoustic setting up

AB	Base setting up
AS	Low noise setting up
AX	eXtra low noise setting up

Source temperature level

M	Medium temperature level
A	High temperature level

Unit description

This series of air-water chillers and heat pumps satisfies the cooling and heating requirements of residential plants of large size.

All the units are suitable for outdoor installation and can be applied to fan coil plants, radiant floor plants and high efficiency radiators plants.

The refrigerant circuit, contained in a compartment protected from the air flow to simplify the maintenance operations, is equipped with scroll compressors mounted on damper supports, brazed plate heat exchanger, electronic expansion valve, reverse cycle valve, dehydrator filter, axial fans with safety protection grill-

les, finned coil made of copper pipes and aluminium louvered fins. The circuit is protected by a safety gas valve, high and low pressure switches and differential pressure switch on the plate heat exchanger.

The plate heat exchanger and all the hydraulic pipes are thermally insulated in order to avoid condensate generation and to reduce thermal losses.

All the units can be equipped with variable speed fans control that allows the units to operate with low outdoor temperatures in cooling and high outdoor temperature in heating and permits to reduce noise emissions in such operating conditions.

The low noise acoustic setting up (AS) is obtained, starting from the base setting up (AB), reducing the rotational speed of the fans and mounting sound jackets on the compressors and the technical compartment is clad with soundproofing material of suitable thickness.

The eXtra low noise acoustic setting up (AX) is obtained, starting from the low noise setting up (AS), further reducing the rotational speed of the fans and using finned coil with bigger surface.

All the units are supplied with a management and control electrical panel containing general switch, phase presence and correct sequence controller, microprocessor controller with display and all the other electrical components with IP54 minimum protection degree.

All the units are accurately built and individually tested in the factory. Only electric and hydraulic connections are required for installation.

Options

[Storing and pumping module](#) available in the configurations :

- storage tank arranged as buffer on the flow or as primary-secondary buffer
- 1 or 2 pumps
- standard or high head pump

[Refrigerant circuit pressures visualization](#)

- high and low pressure gauges
- high and low pressure transducers

[High temperature thermostat](#)

[Compressor starting](#)

- standard (contactors)
- soft starter

[Fans control](#)

- on-off control
- modulating control (condensation / evaporation control) standard for AS and AX unit

[Compressor power factor correction](#)

[Electrical load protection](#)

- fuses
- thermal magnetic circuit breakers

Accessories

[Rubber vibration dampers](#)

[Spring vibration dampers](#)

[Coil protection grilles](#)

[Tank antifreeze electrical heater](#)

[Remote control](#)

[Modbus serial interface on RS485](#)

[Programmer clock](#)

[Phase sequence and voltage controller](#)

[Water flow switch](#)

[Viciaulic hydraulic fittings](#)

NET NOMINAL performances - Standard plants - EUROVENT certified data

IR	Base setting up (AB)	350.5	390.6	440.6	490.6	
A35W7	Cooling capacity	371	398	457	512	kW
	Power input	118	127	146	163	kW
	EER	3,14	3,13	3,13	3,14	W/W
	ESEER	4,27	4,29	4,25	4,29	W/W
	Water flow rate	17,8	19,1	21,9	24,6	l/s
	Pressure drops	33	38	29	37	kPa
IR	Low noise setting up (AS)	350.5	390.6	440.6	490.6	
A35W7	Cooling capacity	356	382	439	491	kW
	Power input	125	134	154	172	kW
	EER	2,85	2,85	2,85	2,85	W/W
	ESEER	4,15	4,15	4,13	4,16	W/W
	Water flow rate	17,1	18,3	21,1	23,6	l/s
	Pressure drops	31	35	27	34	kPa
IR	eXtra low noise setting up (AX)	350.5	390.6	440.6	490.6	
A35W7	Cooling capacity	349	374	429	482	kW
	Power input	126	136	156	175	kW
	EER	2,77	2,75	2,75	2,75	W/W
	ESEER	4,33	4,33	4,29	4,31	W/W
	Water flow rate	16,8	18,0	20,6	23,1	l/s
	Pressure drops	30	34	26	32	kPa
IP	Base setting up (AB)	350.5	390.6	440.6	490.6	
A35W7	Cooling capacity	365	392	448	497	kW
	Power input	117	126	144	160	kW
	EER	3,12	3,11	3,11	3,11	W/W
	ESEER	4,24	4,26	4,23	4,25	W/W
	Water flow rate	17,5	18,8	21,5	23,9	l/s
	Pressure drops	32	37	28	35	kPa
A7W45	Heating capacity	387	417	475	534	kW
	Power input	120	129	147	165	kW
	COP	3,23	3,23	3,23	3,24	W/W
	Water flow rate	18,4	19,8	22,6	25,4	l/s
Pressure drops	36	41	31	39	kPa	
IP	Low noise setting up (AS)	350.5	390.6	440.6	490.6	
A35W7	Cooling capacity	350	376	430	478	kW
	Power input	124	133	152	169	kW
	EER	2,82	2,83	2,83	2,83	W/W
	ESEER	4,12	4,12	4,10	4,12	W/W
	Water flow rate	16,8	18,1	20,6	22,9	l/s
	Pressure drops	30	34	26	32	kPa
A7W45	Heating capacity	372	399	456	513	kW
	Power input	113	121	139	156	kW
	COP	3,29	3,30	3,28	3,29	W/W
	Water flow rate	17,7	19,0	21,7	24,4	l/s
Pressure drops	33	38	28	36	kPa	
IP	eXtra low noise setting up (AX)	350.5	390.6	440.6	490.6	
A35W7	Cooling capacity	343	368	421	468	kW
	Power input	125	134	154	171	kW
	EER	2,74	2,74	2,73	2,74	W/W
	ESEER	4,29	4,29	4,26	4,29	W/W
	Water flow rate	16,5	17,7	20,2	22,5	l/s
	Pressure drops	29	33	25	31	kPa
A7W45	Heating capacity	368	395	451	507	kW
	Power input	109	118	134	151	kW
	COP	3,38	3,35	3,37	3,36	W/W
	Water flow rate	17,5	18,8	21,5	24,1	l/s
Pressure drops	32	37	28	35	kPa	

Data declared according to **EN 14511**. The values are referred to units without options and accessories.

EER (Energy Efficiency Ratio) = ratio of the total cooling capacity to the effective power input of the unit

COP (Coefficient Of Performance) = ratio of the total heating capacity to the effective power input of the unit

ESEER (European Seasonal Energy Efficiency Ratio)
= Unit in **A CLASS**.

A35W7 = source : air in 35°C d.b. / plant : water in 12°C out 7°C

A35W18 = source : air in 35°C d.b. / plant : water in 23°C out 18°C

A7W45 = source : air in 7°C d.b. 6°C w.b. / plant : water in 40°C out 45°C

A7W35 = source : air in 7°C d.b. 6°C w.b. / plant : water in 30°C out 35°C

Acoustic performances

Base setting up (AB)	350.5	390.6	440.6	490.6	
Sound power level ^(E)	95	95	96	96	dB(A)
Sound pressure level at 1 meter	75	75	76	76	dB(A)
Sound pressure level at 5 meters	67	67	68	68	dB(A)
Sound pressure level at 10 meters	63	63	64	64	dB(A)
Low noise setting up (AS)	350.5	390.6	440.6	490.6	
Sound power level ^(E)	89	89	90	90	dB(A)
Sound pressure level at 1 meter	69	69	70	70	dB(A)
Sound pressure level at 5 meters	61	61	62	62	dB(A)
Sound pressure level at 10 meters	57	57	58	58	dB(A)
eXtra low noise setting up (AX)	350.5	390.6	440.6	490.6	
Sound power level ^(E)	86	86	87	87	dB(A)
Sound pressure level at 1 meter	66	66	67	67	dB(A)
Sound pressure level at 5 meters	58	58	59	59	dB(A)
Sound pressure level at 10 meters	54	54	55	55	dB(A)

(E): EUROVENT certified data

The acoustic performances are referred to units operating in cooling mode at nominal conditions A35W7.

Unit placed in free field on reflecting surface (directional factor equal to 2).

The sound power level is measured according to ISO 9614 standard.

The sound pressure level is calculated according to ISO 3744 and is referred to a distance of 1/5/10 metres from the external surface of the unit.

Technical data

Unit	350.5	390.6	440.6	490.6	
Power supply	400 - 3 - 50				V-ph-Hz
Compressor type	scroll				-
N° compressors / N° refrigerant circuits	5 / 2	6 / 2			n°
Plant side heat exchanger type	stainless steel brazed plates				-
Source side heat exchanger type	finned coil				-
Fans type	axial				-
N° fans	8	10			n°
Tank volume	700				l
Hydraulic fittings	4" VICTAULIC				-

Electrical data

Standard unit	350.5	390.6	440.6	490.6	
FLA - Full load current at maximum tolerated conditions	171	182	211	237	A
FLI - Full load power input at maximum tolerated conditions	287	302	355	399	kW
MIC - Maximum instantaneous current of the unit	538	529	605	649	A
MIC SS - Maximum instantaneous current of the unit with soft starter options	414	421	481	525	A
Unit with high head modulating pump	350.5	390.6	440.6	490.6	
FLA - Full load current at maximum tolerated conditions	184	195	227	253	A
FLI - Full load power input at maximum tolerated conditions	308	323	382	426	kW
MIC - Maximum instantaneous current of the unit	558	550	632	676	A
MIC SS - Maximum instantaneous current of the unit with soft starter options	434	441	508	552	A

Operative range

Temperature	Unit type	Cooling		Heating		
		min	max	min	max	
Outdoor air inlet temperature	IR, BR, IP, BP	-10*	52**	-15	40*	(°C)
Water outlet temperature	IR, IP	5	25	30	55	(°C)
Water outlet temperature	BR, BP	-12	5	30	55	(°C)
Water outlet temperature (VD)	IR, BR, IP, BP	30	70	30	70	(°C)
Water outlet temperature (VR)	IR, BR	30	55	-	-	(°C)

* with fans modulating control option (condensation / evaporation control)

** with ATC outdoor high temperature protection function

VD and VR versions

These units allow to recover the heating power, otherwise wasted on air, through an additional heat exchanger.

The **Desuperheater Version (VD)** allow the hot water production at temperatures between 30 and 70°C through the partial heat recovery of the condensation heat.

The **Total Recovery Version (VR)** allows the cold water production and, at the same time, the hot water production at temperatures between 30 and 55°C through the total recovery of the condensation heat.

Desupeheater Version (VD) - NET NOMINAL performances

IR	Base setting up (AB)	350.5	390.6	440.6	490.6	
A35W7 - W45	Cooling capacity	386	413	475	532	kW
	Total power input	115,6	123,8	142,6	159,1	kW
	EER	3,34	3,34	3,33	3,34	W/W
	HRE	4,21	4,22	4,21	4,23	W/W
	Water flow rate	18,5	19,9	22,8	25,6	l/s
	Water pressure drop	36	41	31	40	kPa
	Heating recovery capacity	101	109	125	140	kW
	Water flow rate recovery	4,82	5,20	5,96	6,71	l/s
	Water pressure drop recovery	24	27	25	32	kPa
IP	Base setting up (AB)	350.5	390.6	440.6	490.6	
A35W7 - W45	Cooling capacity	380	407	466	517	kW
	Total power input	114,5	122,7	140,5	155,9	kW
	EER	3,32	3,32	3,31	3,32	W/W
	HRE	4,12	4,12	4,11	4,12	W/W
	Water flow rate	18,2	19,6	22,4	24,8	l/s
	Water pressure drop	35	40	30	37	kPa
	Heating recovery capacity	92	98	112	125	kW
	Water flow rate recovery	4,38	4,70	5,35	5,97	l/s
	Water pressure drop recovery	20	22	20	25	kPa

Total Recovery Version (VR) - NET NOMINAL performances

IR	Base setting up (AB)	350.5	390.6	440.6	490.6	
A35W7 - W45	Cooling capacity	386	413	475	532	kW
	Total power input	100	108	123	140	kW
	EER	3,85	3,81	3,85	3,81	W/W
	HRE	8,65	8,58	8,65	8,57	W/W
	Water flow rate	18,50	19,9	22,8	25,6	l/s
	Water pressure drop	36	41	31	40	kPa
	Heating recovery capacity	481	516	592	665	kW
	Water flow rate recovery	23,0	24,7	28,3	31,8	l/s
	Water pressure drop recovery	52	59	48	61	kPa

Data declared according to EN 14511. The values are referred to units without options and accessories.

EER (Energy Efficiency Ratio) = ratio of the total cooling capacity to the effective power input of the unit

HRE (Heat Recovery Efficiency) = ratio of the total capacity of the system (heating plus cooling capacity) to the effective power input

A35W7 - W45 = source : air in 35°C d.b. / plant : water in 12°C out 7°C / Recovery : water in 40°C out 45°C

CONTROL SYSTEM

The units are equipped with a controller designed to ensure energy saving and unit efficiency. Available functions :

- ATC outdoor high temperature protection function
- Dynamic defrost
- Sound management
- Climatic control in heating and in cooling mode
- Double set point function
- Demand limit
- Integrative heating
- Remote stand by
- Remote cooling-heating



DIMENSIONS - MINIMUM OPERATING AREA - WEIGHT

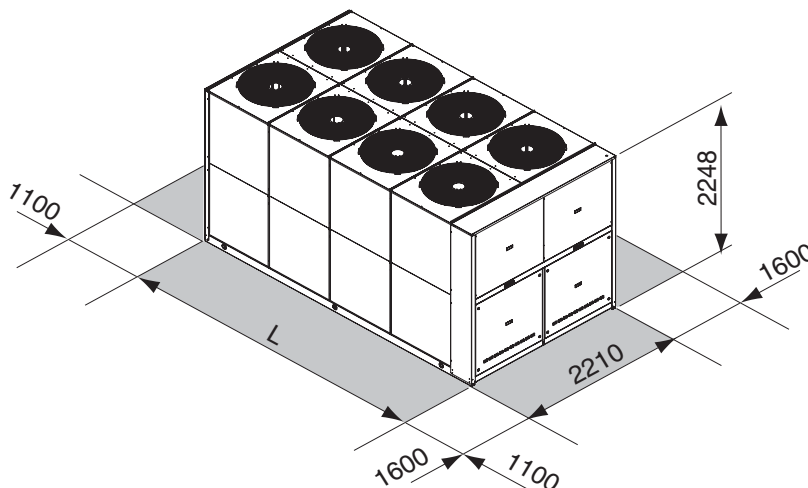

	350.5	390.6	440.6	490.6	
L	5030	5030	5030	5030	mm
Operating maximum weight*	4900	5110	5220	5300	kg

* Weight refers to the unit IP with tank and pumping module 2 pumps.

> RHA ST

AIR-WATER CHILLERS AND HEAT PUMPS FOR OUTDOOR INSTALLATION



Available range

Unit type

IR	Chiller
IP	Heat pump (reversible on the refrigerant side)
BR	Chiller Brine
BP	Heat pump Brine (reversible on the refrigerant side)

Version

VB	Base version
VD	Desuperheater version (with plate heat exchanger)
VR	Total recovery version (with plate heat exchanger)

Acoustic setting up

AB	Base setting up
AS	Low noise setting up
AX	eXtra low noise setting up

Source temperature level

M	Medium temperature level
A	High temperature level

Unit description

This series of air-water chillers and heat pumps satisfies the cooling and heating requirements of residential plants of large size.

All the units are suitable for outdoor installation and can be applied to fan coil plants, radiant floor plants and high efficiency radiators plants.

The refrigerant circuit, contained in a compartment protected from the air flow to simplify the maintenance operations, is equipped with scroll compressors mounted on damper supports, shell and tube heat exchanger with threaded or

victaulic fittings (according to the model), electronic expansion valve, reverse cycle valve, dehydrator filter, axial fans with safety protection grilles, finned coil made of copper pipes and aluminium louvered fins. The circuit is protected by a safety gas valve, high and low pressure switches and differential pressure switch on the heat exchanger.

The heat exchanger and all the hydraulic pipes are thermally insulated in order to avoid condensate generation and to reduce thermal losses.

All the units can be equipped with variable speed fans control that allows the units to operate with low outdoor temperatures in cooling and high outdoor temperature in heating and permits to reduce noise emissions in such operating conditions.

The low noise acoustic setting up (AS) is obtained, starting from the base setting up (AB), reducing the rotational speed of the fans and mounting sound jackets on the compressors and the technical compartment is clad with soundproofing material of suitable thickness.

The eXtra low noise acoustic setting up (AX) is obtained, starting from the low noise setting up (AS), further reducing the rotational speed of the fans and using finned coil with bigger surface.

All the units are supplied with a management and control electrical panel containing general switch, phase presence and correct sequence controller, microprocessor controller with display and all the other electrical components with IP54 minimum protection degree.

All the units are accurately built and individually tested in the factory. Only electric and hydraulic connections are required for installation.

Options

Storing module available in the configurations :

- 1 or 2 pumps
- standard or high head pump
- Refrigerant circuit pressures visualization**
- high and low pressure gauges
- high and low pressure transducers

High temperature thermostat

Compressor starting

- standard (contactors)
- soft starter

Fans control

- on-off control
- modulating control (condensation / evaporation control) standard for AS and AX unit

Compressor power factor correction

Electrical load protection

- fuses
- thermal magnetic circuit breakers

Accessories

Rubber vibration dampers

Spring vibration dampers

Coil protection grilles

Remote control

Modbus serial interface on RS485

Programmer clock

Phase sequence and voltage controller

Water flow switch

Victaulic hydraulic fittings

NET NOMINAL performances - Standard plants - EUROVENT certified data

IR	Base setting up (AB)	350.5	390.6	440.6	490.6	560.6	630.6	
A35W7	Cooling capacity	348	371	436	489	554	619	kW
	Power input	123	131	152	174	193	219	kW
	EER	2,83	2,83	2,87	2,81	2,87	2,83	W/W
	ESEER	3,90	3,90	3,93	3,90	3,94	3,91	W/W
	Water flow rate	16,8	17,9	21,0	23,6	26,7	29,9	l/s
	Pressure drops	36	35	50	67	39	67	kPa
IR	Low noise setting up (AS)	350.5	390.6	440.6	490.6	560.6	630.6	
A35W7	Cooling capacity	335	356	418	470	532	595	kW
	Power input	129	140	162	185	207	233	kW
	EER	2,60	2,54	2,58	2,54	2,57	2,55	W/W
	ESEER	3,78	3,74	3,77	3,74	3,76	3,75	W/W
	Water flow rate	16,1	17,2	20,1	22,6	25,6	28,7	l/s
	Pressure drops	33	32	46	62	36	62	kPa
IR	eXtra low noise setting up (AX)	350.5	390.6	440.6	490.6	560.6	630.6	
A35W7	Cooling capacity	328	349	410	460	522	583	kW
	Power input	133	144	166	190	211	239	kW
	EER	2,47	2,42	2,47	2,42	2,47	2,44	W/W
	ESEER	3,87	3,84	3,89	3,84	3,88	3,86	W/W
	Water flow rate	15,8	16,8	19,7	22,2	25,1	28,1	l/s
	Pressure drops	32	31	44	59	35	59	kPa
IP	Base setting up (AB)	350.5	390.6	440.6	490.6	560.6	630.6	
A35W7	Cooling capacity	339	361	423	476	536	603	kW
	Power input	120	130	151	171	191	216	kW
	EER	2,83	2,78	2,80	2,78	2,81	2,79	W/W
	ESEER	3,85	3,83	3,84	3,84	3,85	3,85	W/W
	Water flow rate	16,3	17,4	20,4	22,9	25,8	29,0	l/s
	Pressure drops	34	33	47	63	37	63	kPa
A7W45	Heating capacity	373	397	460	521	580	664	kW
	Power input	123	132	152	174	192	223	kW
	COP	3,03	3,01	3,03	2,99	3,02	2,98	W/W
	Water flow rate	17,7	18,8	21,8	24,7	27,5	31,4	l/s
Pressure drops	40	38	54	74	41	74	kPa	
IP	Low noise setting up (AS)	350.5	390.6	440.6	490.6	560.6	630.6	
A35W7	Cooling capacity	325	346	406	457	515	579	kW
	Power input	128	138	161	183	204	231	kW
	EER	2,54	2,51	2,52	2,50	2,52	2,51	W/W
	ESEER	3,70	3,69	3,69	3,67	3,67	3,69	W/W
	Water flow rate	15,6	16,7	19,5	22,0	24,7	27,9	l/s
	Pressure drops	31	30	44	59	33	58	kPa
A7W45	Heating capacity	358	380	441	500	557	638	kW
	Power input	118	125	145	166	184	213	kW
	COP	3,03	3,04	3,04	3,01	3,03	3,00	W/W
	Water flow rate	17,0	18,0	20,9	23,7	26,4	30,2	l/s
Pressure drops	37	35	50	68	38	69	kPa	
IP	eXtra low noise setting up (AX)	350.5	390.6	440.6	490.6	560.6	630.6	
A35W7	Cooling capacity	319	340	397	447	505	568	kW
	Power input	131	140	165	187	209	236	kW
	EER	2,44	2,43	2,41	2,39	2,42	2,41	W/W
	ESEER	3,83	3,81	3,79	3,79	3,79	3,79	W/W
	Water flow rate	15,3	16,3	19,1	21,5	24,3	27,3	l/s
	Pressure drops	30	29	42	56	32	56	kPa
A7W45	Heating capacity	355	376	436	495	551	631	kW
	Power input	116	123	142	163	180	209	kW
	COP	3,06	3,06	3,07	3,04	3,06	3,02	W/W
	Water flow rate	16,8	17,8	20,7	23,4	26,1	29,9	l/s
Pressure drops	36	35	49	66	37	67	kPa	

Data declared according to EN 14511. The values are referred to units without options and accessories.

EER (Energy Efficiency Ratio) = ratio of the total cooling capacity to the effective power input of the unit

COP (Coefficient Of Performance) = ratio of the total heating capacity to the effective power input of the unit

ESEER (European Seasonal Energy Efficiency Ratio)

A35W7 = source : air in 35°C d.b. / plant : water in 12°C out 7°C

A35W18 = source : air in 35°C d.b. / plant : water in 23°C out 18°C

A7W45 = source : air in 7°C d.b. 6°C w.b. / plant : water in 40°C out 45°C

A7W35 = source : air in 7°C d.b. 6°C w.b. / plant : water in 30°C out 35°C

Acoustic performances

Base setting up (AB)	350.5	390.6	440.6	490.6	560.6	630.6	
Sound power level	95	95	96	96	97	97	dB(A)
Sound pressure level at 1 meter	75	75	76	76	76	76	dB(A)
Sound pressure level at 5 meters	67	67	68	68	69	69	dB(A)
Sound pressure level at 10 meters	63	63	64	64	65	65	dB(A)
Low noise setting up (AS)	350.5	390.6	440.6	490.6	560.6	630.6	
Sound power level	89	89	90	90	91	91	dB(A)
Sound pressure level at 1 meter	69	69	70	70	70	70	dB(A)
Sound pressure level at 5 meters	61	61	62	62	63	63	dB(A)
Sound pressure level at 10 meters	57	57	58	58	59	59	dB(A)
eXtra low noise setting up (AX)	350.5	390.6	440.6	490.6	560.6	630.6	
Sound power level	86	86	87	87	88	88	dB(A)
Sound pressure level at 1 meter	66	66	67	67	67	67	dB(A)
Sound pressure level at 5 meters	58	58	59	59	60	60	dB(A)
Sound pressure level at 10 meters	54	54	55	55	56	56	dB(A)

The acoustic performances are referred to units operating in cooling mode at nominal conditions A35W7.

Unit placed in free field on reflecting surface (directional factor equal to 2).

The sound power level is measured according to ISO 9614 standard.

The sound pressure level is calculated according to ISO 3744 and is referred to a distance of 1/5/10 metres from the external surface of the unit.

Technical data

Unit	350.5	390.6	440.6	490.6	560.6	630.6	
Power supply	400 - 3 - 50						V-ph-Hz
Compressor type	scroll						-
N° compressors / N° refrigerant circuits	5 / 2	6 / 2					n°
Plant side heat exchanger type	shell and tube						-
Source side heat exchanger type	finned coil						-
Fans type	axial						-
N° fans	8	10		12			n°
Water volume plant side heat exchanger	93.9	87.5	80.2	80.2	124.7	113.5	l
Hydraulic fittings plant side heat exchanger	5" VIC			6" VIC			-

Electrical data

Standard unit	350.5	390.6	440.6	490.6	560.6	630.6	
FLA - Full load current at maximum tolerated conditions	287	302	355	399	451	494	A
FLI - Full load power input at maximum tolerated conditions	171	182	211	237	272	304	kW
MIC - Maximum instantaneous current of the unit	538	529	605	649	771	815	A
MIC SS - Maximum instantaneous current of the unit with soft starter options	434	441	508	552	640	684	A
Unit with high head modulating pump	350.5	390.6	440.6	490.6	560.6	630.6	
FLA - Full load current at maximum tolerated conditions	308	323	382	426	478	521	A
FLI - Full load power input at maximum tolerated conditions	184	195	227	253	288	320	kW
MIC - Maximum instantaneous current of the unit	558	550	632	676	798	842	A
MIC SS - Maximum instantaneous current of the unit with soft starter options	558	550	632	676	798	842	A

Operative range

Temperature	Unit type	Cooling		Heating		
		min	max	min	max	
Outdoor air inlet temperature	IR, BR, IP, BP	-10*	52**	-10	40*	(°C)
Water outlet temperature	IR, IP	5	15	30	55	(°C)
Water outlet temperature	BR, BP	-12	5	30	55	(°C)
Water outlet temperature (VD)	IR, BR, IP, BP	30	70	30	70	(°C)
Water outlet temperature (VR)	IR, BR	30	55	-	-	(°C)

* with fans modulating control option (condensation / evaporation control)

** with ATC outdoor high temperature protection fuccion

VD and VR versions

These units allow to recover the heating power, otherwise wasted on air, through an additional plate heat exchanger.

The **Desuperheater Version (VD)** allow the hot water production at temperatures between 30 and 70°C through the partial heat recovery of the condensation heat.

The **Total Recovery Version (VR)** allows the cold water production and, at the same time, the hot water production at temperatures between 30 and 55°C through the total recovery of the condensation heat.

Desupeheater Version (VD) - NET NOMINAL performances

IR	Base setting up (AB)	350.5	390.6	440.6	490.6	560.6	630.6	
A35W7 - W45	Cooling capacity	362	385	453	509	576	644	kW
	Total power input	120	129	150	170	189	213	kW
	EER	3,02	3	3,03	2,99	3,06	3,02	W/W
	HRE	3,75	3,72	3,76	3,71	3,79	3,75	W/W
	Water flow rate	17,5	18,6	21,8	24,6	27,8	31,0	l/s
	Water pressure drop	39	38	54	72	42	73	kPa
	Heating recovery capacity	87,7	93,4	110	123	139	156	kW
	Water flow rate recovery	4,19	4,46	5,26	5,88	6,64	7,45	l/s
	Water pressure drop recovery	24	27	25	32	31	39	kPa
	IP	Base setting up (AB)	350.5	390.6	440.6	490.6	560.6	630.6
A35W7 - W45	Cooling capacity	352	376	440	494	558	626	kW
	Total power input	118	126	147	168	187	211	kW
	EER	2,99	2,97	2,98	2,94	2,98	2,97	W/W
	HRE	3,72	3,69	3,7	3,66	3,71	3,69	W/W
	Water flow rate	16,9	18,1	21,2	23,9	26,8	30,2	l/s
	Water pressure drop	36	36	51	69	39	69	kPa
	Heating recovery capacity	85,2	90,7	106	120	135	152	kW
	Water flow rate recovery	4,07	4,33	5,06	5,73	6,45	7,26	l/s
	Water pressure drop recovery	23	26	24	30	29	36	kPa

Total Recovery Version (VR) - NET NOMINAL performances

IR	Base setting up (AB)	350.5	390.6	440.6	490.6	560.6	630.6	
A35W7 - W45	Cooling capacity	362	385	453	509	576	644	kW
	Total power input	104	113	130	150	166	190	kW
	EER	3,48	3,42	3,49	3,38	3,48	3,38	W/W
	HRE	7,92	7,8	7,94	7,72	7,92	7,72	W/W
	Water flow rate	17,5	18,6	21,8	24,6	27,8	31,0	l/s
	Water pressure drop	39	38	55	74	43	74	kPa
	Heating recovery capacity	461	493	577	652	734	824	kW
	Water flow rate recovery	22	23,6	27,6	31,2	35,1	39,4	l/s
	Water pressure drop recovery	52	60	51	66	54	68	kPa

Data declared according to **EN 14511**. The values are referred to units without options and accessories.
EER (Energy Efficiency Ratio) = ratio of the total cooling capacity to the effective power input of the unit
HRE (Heat Recovery Efficiency) = ratio of the total capacity of the system (heating plus cooling capacity) to the effective power input
A35W7 - W45 = source : air in 35°C d.b. / plant : water in 12°C out 7°C / Recovery : water in 40°C out 45°C

CONTROL SYSTEM

The units are equipped with a controller designed to ensure energy saving and unit efficiency. Available functions :

- ATC outdoor high temperature protection function
- Dynamic defrost
- Sound management
- Climatic control in heating and in cooling mode
- Double set point function
- Demand limit
- Integrative heating
- Remote stand by
- Remote cooling-heating



DIMENSIONS - MINIMUM OPERATING AREA - WEIGHT

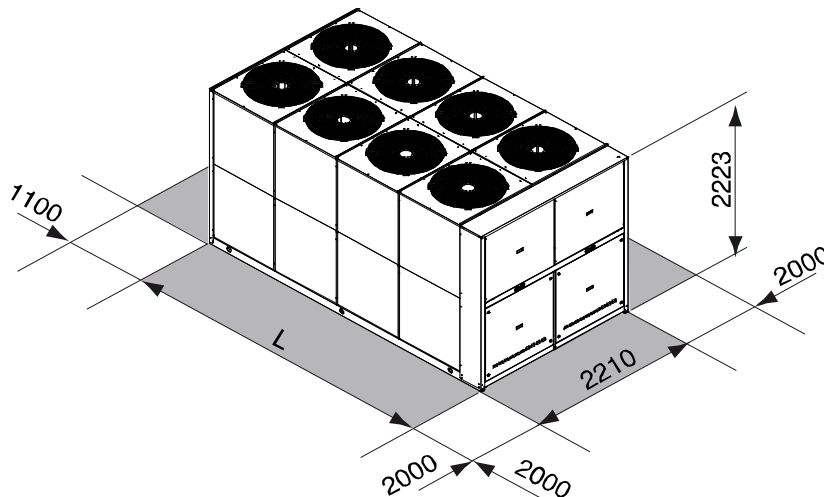

	350.5	390.6	440.6	490.6	560.6	630.6	
L	5030	5030	5030	5030	5963	5963	mm
Operating maximum weight*	3853	4053	4087	4166	4477	4560	kg

* Weight refers to the unit IP complete with 2 pumps module without tank.